

Sapphire Series

Espagnolettes System



Doric

Sapphire Series *Espagnolettes System*

Features

- Solidly built with quality materials
- Positive and smooth handling
- Drives locking points easily
- Can be fitted on most sections

Material

Handle & Base:	Die-Cast Zinc
Drive shaft (7mm sq):	Die-Cast Zinc
Sliding Bar:	SS 304
Locking Pins:	SS 304
Finish Available:	Black and White

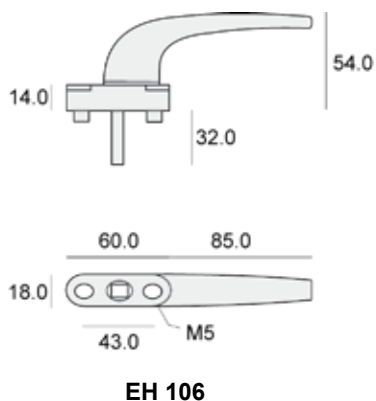

Slide Bar

Model	Bar Length (X)	Pin Length (Y)
EB20-350	350mm	240mm
EB20-400	400mm	290mm
EB20-600	600mm	490mm
EB20-800	800mm	690mm
EB20-1,000	1,000mm	890mm
EB20-1,200	1,200mm	1,090mm

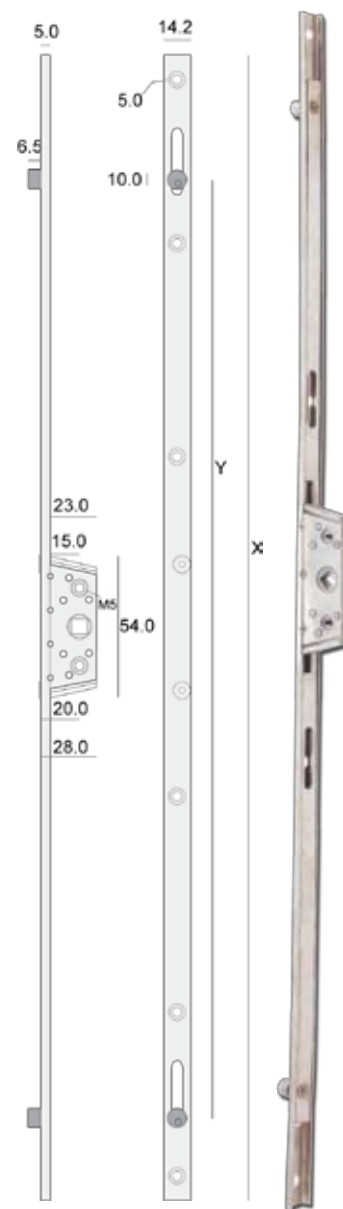

Slide Bar

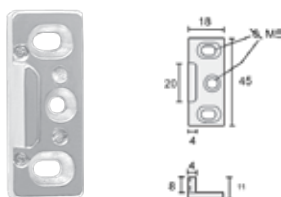

FKP Keeper