

**Platinum Friction Stays - Heavy Duty**  
*Manufactured in 304 Austenitic Stainless Steel*



# Platinum Friction Stays - Heavy Duty

Manufactured in 304 Austenitic Stainless Steel to ensure corrosion free performance, with solid core spin riveted components for geometrical accuracy.

## Features

- Large rectangular channel profile for better friction control
- Combination of nylon & stainless steel slider components for smooth and accurate sliding
- Polished surface for smoother operation and ease of cleaning
- Non handed design to enable ease and flexibility of fitting
- Suitable for Casement and Awning windows

## Technical Specifications

|                |                                   |
|----------------|-----------------------------------|
| Bar Thickness: | Channel - 1.2mm<br>Arms - 2.5mm   |
| Bar Width:     | Channel - 22.0mm<br>Arms - 19.0mm |

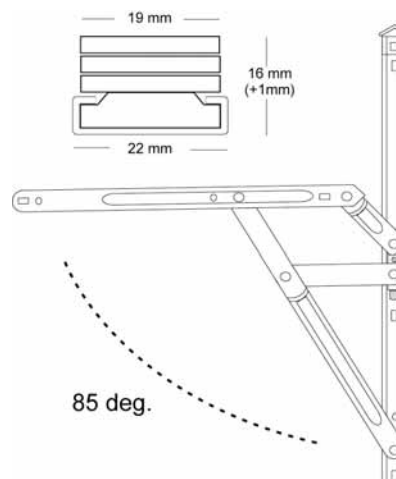

## Tested to British & European Standards:



| Top Hung     |      |                      |                 |                  |             |         |
|--------------|------|----------------------|-----------------|------------------|-------------|---------|
| Product Code | Size | Stack Height (+ 1mm) | Max. Vent Width | Max. Vent Height | Max. Weight | Opening |
| PH-10        | 10"  | 16 mm                | 1910 mm         | 770 mm           | 50 kg       | 85 deg. |
| PH-16        | 16"  | 16 mm                | 1830 mm         | 1120 mm          | 70 kg       | 85 deg. |
| PH-22        | 22"  | 16 mm                | 1630 mm         | 1320 mm          | 74 kg       | 85 deg. |

| Side Hung    |      |                      |                       |                  |             |         |
|--------------|------|----------------------|-----------------------|------------------|-------------|---------|
| Product Code | Size | Stack Height (+ 1mm) | Max. Vent Width       | Max. Vent Height | Max. Weight | Opening |
| PH-10        | 10"  | 16 mm                | 670 mm                | 1530 mm          | 35 kg       | 85 deg. |
| PH-16        | 16"  | 16 mm                | 770 mm                | 1620 mm          | 42 kg       | 85 deg. |
| PH-22        | 22"  | 16 mm                | Refer to Manufacturer |                  |             |         |

The above is intended as a guide, please contact manufacturer for specific application. Regular maintenance is required on stays fitted in coastal, high humidity and corrosive environments for optimum operation. Doric has a policy of continual product improvement, as such we reserve the right to change specifications without notice.

For top hung windows over 1000mm in height, the opening must be restricted to a maximum of 200mm projection. We recommend Doric Restrictor Arms to be fitted.

**Head Office:** Phone + 61 (0) 2 9609 2555 sales@doric.com.au  
Fax: + 61 (0) 2 9604 2910 www.doric.com.au

